

*inspired by  
craftsmanship*

## **Drillex**

CNC drilling machine for window and door manufacturers



# Drillex

The Drillex is CNC drilling and milling machine with 6 working units, with two moving and one fixed clamping table

The Drillex work centre is designed for drilling of doweling holes, mortising of slots, milling of door lock pockets, hinge seats and bevelled louvre slots.

Intuitive control of the machine is provide by a Beckhoff PC with 12" touch screen which uses data from WinCreator or third party software where all macros are defined. Drillex can be linked to the main Wizard machine from which identification labels can be printed out allowing the drilled pieces to be scanned and processed at the next stage.



Drilling units

Exchangeable drilling heads for handle and window hinges



Three top vertical and three horizontal heads for milling and drilling



Mechanical clamping system HSK 40A for quick tools exchange HSK 40C (optional)

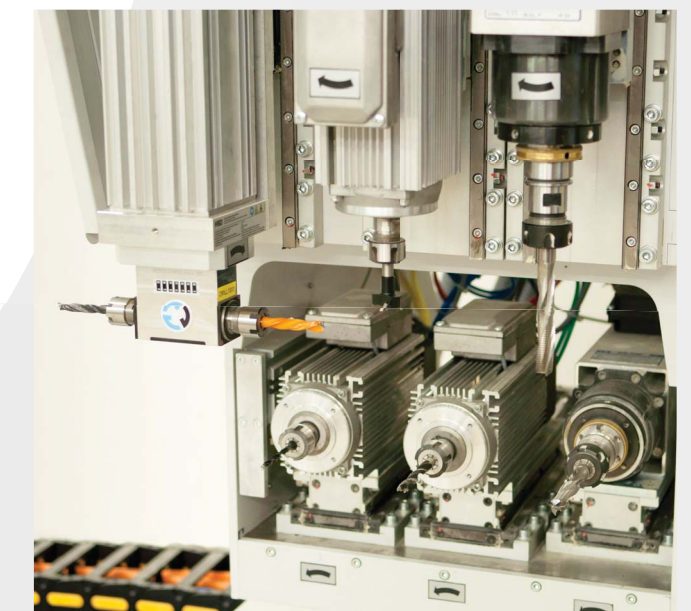
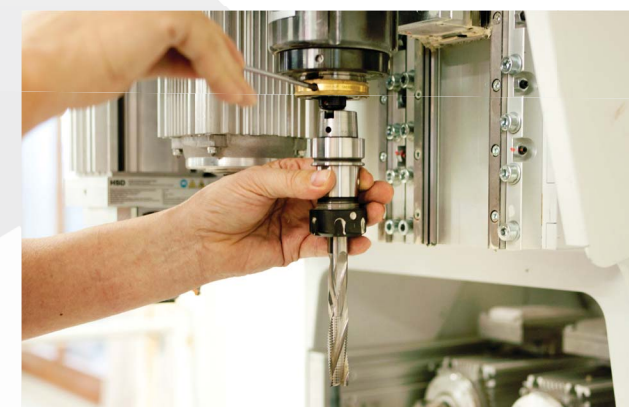



## Examples of processing

The machine is designed for standard operations in window and door manufacturing but the machine can be modified for customer-specific solutions using various accessories.

Head and longitudinal drilling for dowel connection



Mortised slots with rounded tenons, bevelled and dove tail connection



Drilled window hinges



Door 3D and butt hinges



Holes for window handle, mortised for door lock cases, bevelled slots for louvres



## Technical data

- X-axis stroke / length of piece 3400 / 3000 mm
- Y-axis stroke / width of piece 250 / 200 mm
- Z-axis stroke / thickness of piece 150 / 100 mm  
(200 / 140 mm optional)

### Working units

- 2 horizontal drilling units 1,5 HP;  
rpm 3000 for bits up to  $\varnothing$  13 mm
- 1 horizontal milling unit 7,5 HP;  
rpm 0-18000 for bits up to  $\varnothing$  16 mm
- 1 vertical milling unit 7,5 HP;  
rpm 0-18000 for bits up to  $\varnothing$  16 mm
- 1 vertical drilling unit 1,5 HP;  
rpm 3000 for bits up to  $\varnothing$  13 mm
- 1 vertical working unit 2,2 HP;  
rpm 3000 for exchangeable drilling heads
- 1 vertical working unit 2,2 HP;  
3000 rpm with double outlet drilling bits  
(optional instead of one vertical unit)
- HSK 40A mechanical tool holder system  
for milling units (optional)

### Control system

- BECKHOFF industrial PC with 15" touch screen  
Windows Embedded for industrial applications

### Working tables

- 2 moving programmable work tables  
with pneumatic clamps
- 1 fixed table with turning clamping arm for  
longitudinal and cross machining with additional table

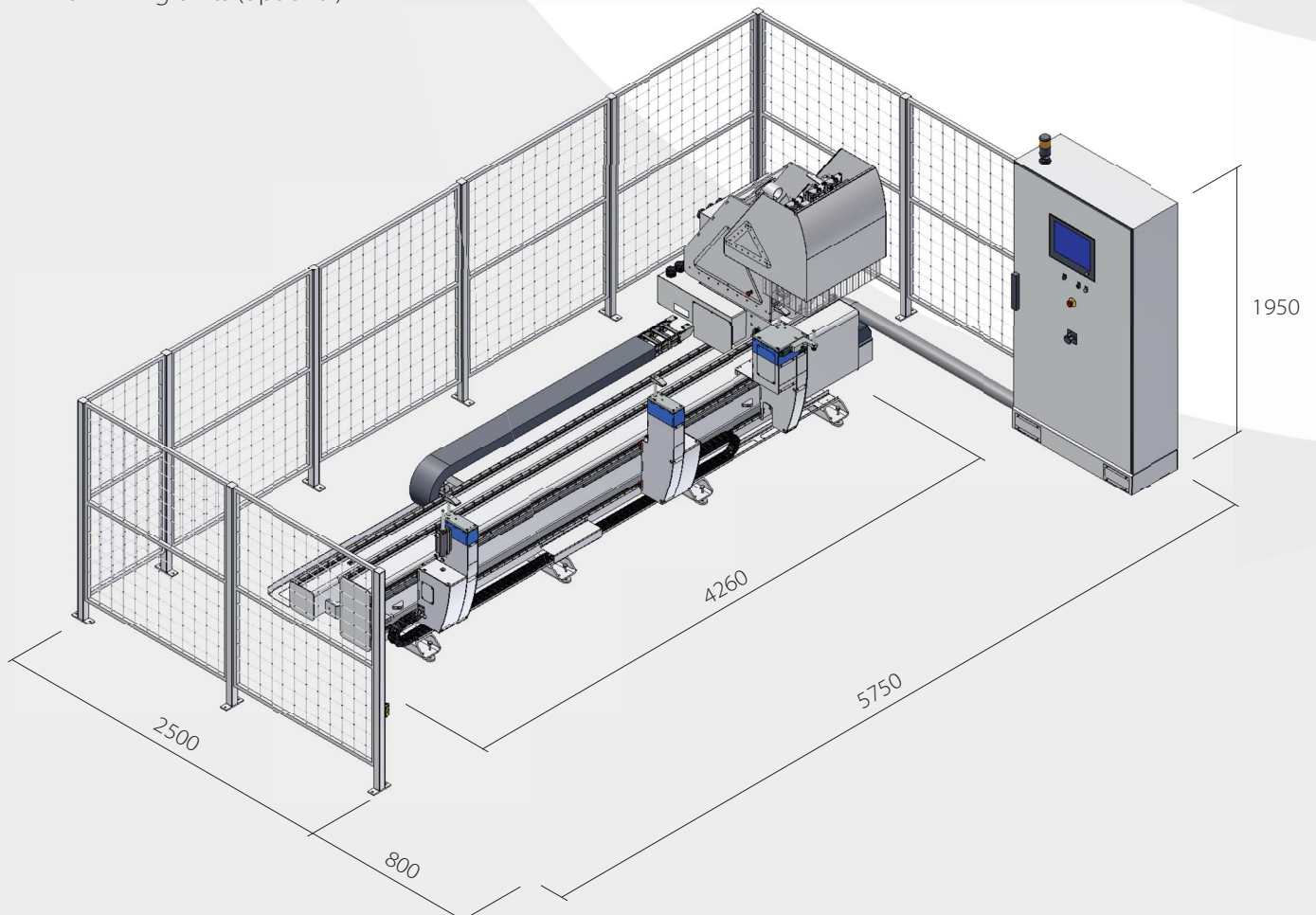



**SOUKUP s.r.o.**  
Komerční 518, 251 02 Prague - Nupaky, Czech Republic  
Tel.: +420 241 403 110, E-mail: [info@soukup.cz](mailto:info@soukup.cz)  
[www.soukup.cz](http://www.soukup.cz)

